

Preflight Inspection – Grob 103

1. Open Canopy
 - Check for foreign bodies - snakes, insects, etc.
 - Check for ballast – remove or install as necessary
 - Check all controls for full and free movement
 - Check canopy jettison mechanism has not been activated
 - Check canopy for damage and clean as necessary
 - Check belts are secure - if flying solo secure rear cushions with belts
 - Check yaw strings and replace if necessary
 - Check tow hook release from front and back seat
 - Check wheel brake
 - Check main wheel tire pressure is 35 - 39 lbs
 - Check nose wheel tire pressure is 35 lbs
2. Check top and bottom of left wing for damage
 - Check wing wheel
 - Check ailerons for freedom of movement and play
 - Check spoiler/airbrake for condition, locking and fit
 - Check spoiler/airbrake for interior dirt
3. Check left fuselage for damage especially on the underside
4. Check elevator for freedom of movement and play
 - Check rudder for freedom of movement and play
5. Check tail wheel tire pressure is 35 lbs
6. Check right fuselage for damage especially on the underside
7. Repeat step 2 for right wing
8. Remove covers from and check pitot, static and total energy vents are clean
9. Perform a Positive Control Check with another pilot
 - Call control movements to ensure they have not been “crossed”*
 - Left aileron - *stick left aileron up - stick right aileron down*
 - Left airbrake - check for open and close pressure
 - Elevator - *stick back elevator up - stick forward elevator down*
 - Rudder - *left pedal rudder left - right pedal rudder right*
 - Right airbrake - check for open and close pressure
 - Right aileron - *stick right aileron up - stick left aileron down*

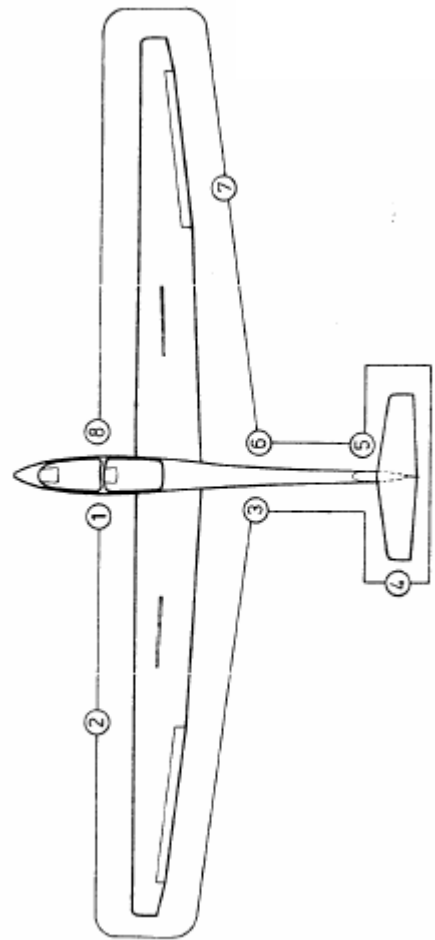

Never leave open canopy unattended